

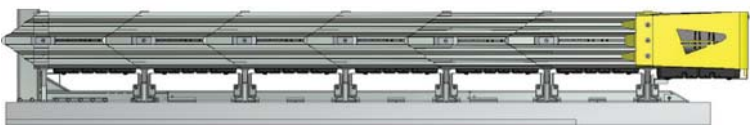

QuadGuard[®] II



TRINITY
HIGHWAY
Ahead of the Curve[™]

QuadGuard® II

The QuadGuard® II consists of an engineered steel nose and crushable, energy absorbing cartridges surrounded by a framework of steel Quad-Beam™ panels. The system is NCHRP Report 350 Test Level 2 and Test Level 3 compliant as a re-directive, non-gating crash cushion. The Test Level 2 QuadGuard II is 25% shorter than the original QuadGuard measuring less than 10' (3 m). The Test Level 3 model is also nearly 3' (1 m), shorter in length than its predecessor. The QuadGuard II can be used to shield fixed objects of 24" to 126" wide (610 mm to 3.2 m) while using less than 19' in length (22' for the 126").

QuadGuard II, as a member of the QuadGuard family of crash cushions, utilizes many of the same components as the QuadGuard.



LESS IS MORE

Features

- Self-supporting steel nose, custom cut-out available.
- Monorail guide stabilizers.
- Anchorage options include: asphalt, concrete, soil-drive pile.
- QuadGuard II has 25% less footprint for TL-2 and 3' less for TL-3 than original QuadGuard.
- High strength Quad-Beam panels.
- Needs no anchoring chains or tension cables.
- Compact, modular design accommodates speeds from 25 mph (40 km/h) to 70 mph (115 km/h).

Back-Up Structure and Attachments

- Simplified backups - Tension strut or concrete
- Bridge pier(s) and parapet(s)
- Square block(s)
- Temporary & permanent concrete barrier(s)
- Thrie-beam
- W-beam

Assembly and Maintenance

- 25% less footprint for TL-2 and 3' less for TL-3, reducing installation costs.
- Damaged cartridges contain debris and are easily replaceable.
- Monorail base eliminates need for anchoring chains/tension cables.
- QuadGuard II may be reusable after design impacts

Specifications

Typical TL-2 Two-bay Unit

(Available in Widths of 24" 30", 36", 48"):

- 9'11" Long (3.03 m)
- 24" (610 mm) Min., 48" (1.22 m) Max. Width at backup structure.
- 1,210 lbs. (549 kg)

Typical TL-3 Five-bay Unit

(Available in Widths of 24", 30", 36", 69", 90", 126" (the 126" is a Six Bay Unit) Custom Widths):

- 19' Long (5.8 m)
- 24" (610 mm) Min., 126" (3.2 m) Max. Width at Backup Structure.
- 2,455 lbs. (1,114 kg)

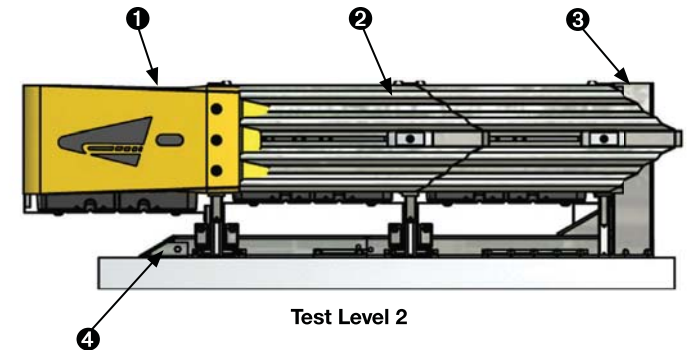

- 1 Engineered Steel Nose
- 2 Fender Panel
- 3 Steel Backup
- 4 Monorail

An original  ENERGY ABSORPTION SYSTEMS, INC. product.

Distributed by:

