

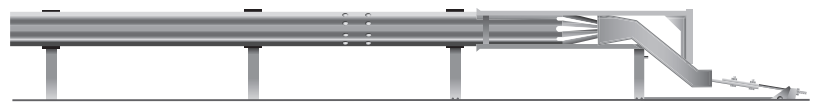

MASH
compliant

SoftStop® System



TRINITY
HIGHWAY

Ahead of the Curve™

SoftStop® System

The SoftStop® System is a tangent, single-sided, energy absorbing, redirective and gating end terminal. The SoftStop System is the first end terminal to meet the evaluation criteria set forth in the Manual for Assessing Safety Hardware (MASH). It is also available in Test Level 1 and Test Level 2 configurations.

During head-on impacts within MASH criteria, the SoftStop System is designed to dissipate energy by the head traveling down the anchored panels. During length-of-need side impacts within MASH criteria, the SoftStop System is designed to contain and redirect the impacting vehicle.

FRONT ANCHOR TECHNOLOGY

Features

- The front anchorage is designed to allow the rail panels to remain anchored during end-on impacts within MASH criteria.
- Narrow head design helps minimize nuisance impacts from vehicles and maintenance operations, such as mowing and snow removal.

Specifications

- MASH Compliant
- Tangent
- Redirective & Gating
- BLON: 16'-6"
- System Length:
 - 50'-9 1/2" (Test Level 3)
 - 38'-3 1/2" (Test Level 2)
 - 25'-9 1/2" (Test Level 1)
- Head Width: 7"

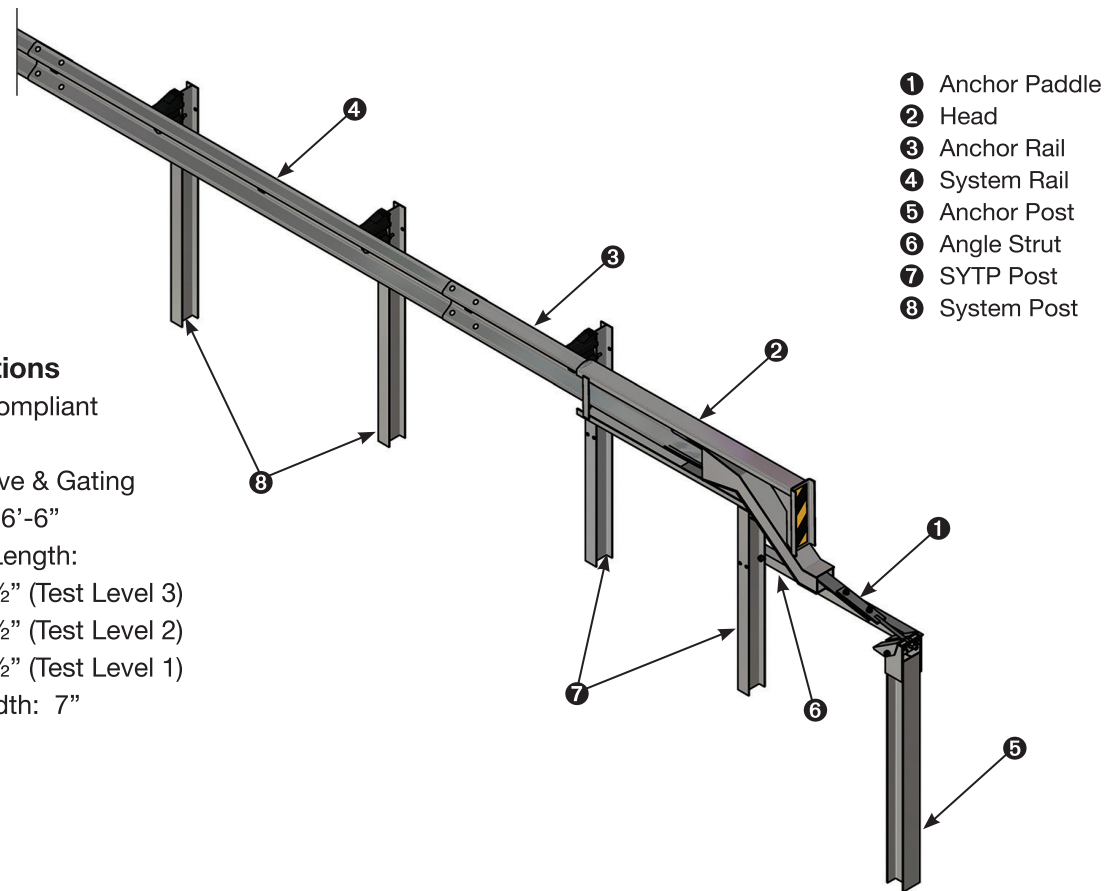

Distributed by:

 **Coral Sales Co.**
Highway Safety Solutions

P. 503-655-6351 » F. 503-657-9649

www.coralsales.com

PO Box 22385 Portland, OR 97269-2385

1-16
www.trinityhighway.com
1.888.323.6374

